

Miniature Low Pressure
Flow-Through Sensors
26PC Series, Compensated/Unamplified
1 psi to 100 psi

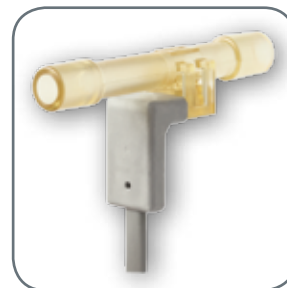

Miniature Low Pressure Flow-Through Sensors

The 26PC Series Miniature Low Pressure Flow-Through Sensors feature proven sensing technology that uses a specialized piezoresistive micromachined sensing element to offer high performance, reliability, and accuracy.

Each sensor contains four active piezoresistive elements in a Wheatstone bridge configuration. When pressure is applied, the resistance changes and provides an output signal in mV proportional to the input pressure.

The low power, compensated, unamplified Wheatstone bridge circuit design offers 1 psi through 100 psi sensing ranges in a variety of pressure port types and termination configurations. The mV output is available in both negative and positive voltage.

Visit www.honeywell.com/sensing to download 3D CAD drawings in IGES and STEP format, and 2D drawings in PDF format.

These sensors are intended for use with media compatible with plastics and media seals specified in the Nomenclature and Order Guide (see Figure 2). (2D drawings also provide plastic housing and port material information.) They are designed and manufactured according to ISO 9001 standards.

What makes our sensors better?

- Selectable seals available to match media used
- Higher pressure ranges for use in high pressure applications
- Minimal dead space inhibits bacterial growth
- Available in both SIP and DIP packages
- Available with cable harness to allow off-board sensing

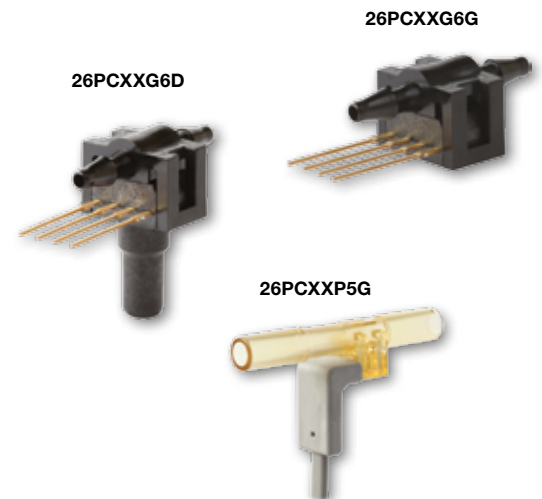

For all available configurations, see Figure 3.

MINIMAL DEAD SPACE • CABLE HARNESS AVAILABLE • SELECTABLE SEALS

Features and Benefits

In-line use minimizes the number of pneumatic connections and helps reduce system dead space.

FLOW THROUGH DESIGN IN MINIATURE, PLASTIC PACKAGE

Provides a reduced-cost alternative (versus stainless steel package)

INTEGRATED FLOW THROUGH DESIGN

Eliminates the need for many additional connections and parts

By matching pressure ranges to the application, we optimize resolution and improve system accuracy.

VARIETY OF PRESSURE RANGES FROM 1 PSI TO 100 PSI

Allows use in a wide variety of applications

ABSOLUTE, DIFFERENTIAL, WET-WET DIFFERENTIAL, GAGE AND VACUUM GAGE MEASUREMENT TYPES

Allow customers to choose the sensor that fits their applications

ROBUST MEDIA COMPATIBILITY

Requires no gel coating

DURABLE

Operable after exposure to frozen conditions

ALSO AVAILABLE IN DIP, SIP, AND SMT PACKAGES

Provides added design flexibility

Potential Applications



MEDICAL

HEMODIALYSIS

May be used to monitor the correct pressure to help ensure optimal blood filtration

Table 1. Absolute Maximum Ratings¹

Characteristic	Min.	Typ.	Max.	Unit	Note
Supply voltage	2.5	10	16	Vdc	–
Input resistance	5.5	7.5	11.5	kOhm	–
Output resistance	1.5	2.5	3	kOhm	–
Time response	–	–	1	ms	2

¹Absolute maximum ratings are the extreme limits the device will withstand without damage.

²Time required for the output to increase from 10% to 90% of span in response to a step change in input pressure from the specified min. to max. operating pressure.

Table 2. Technical Specifications

Characteristic	Parameter
Operating temperature range: without EPDM seals with EPDM seals	-40 °C to 85 °C [-40 °F to 185 °F] -20 °C to 85 °C [-4 °F to 185 °F]
Compensated temperature range	0 °C to 50 °C [32 °F to 122 °F]
Storage temperature range	55 °C to 100 °C [-67 °F to 212 °F]
Soldering terminal temperature/time	315 °C [599 °F] max./10 s max.
Vibration	10 G at 20 Hz to 2000 Hz
Shock	100 G for 11 ms
Life	1 million cycles min.

26PC Series, Compensated/Unamplified

Table 3. Performance Characteristics (Vcc = 10.00 ± 0.01 Vdc; Ta = 25 °C [77 °F])

Characteristic	Operating Pressure Range												Unit	Note
	0 psi to 1 psi		0 psi to 5 psi		0 psi to 15 psi		0 psi to 30 psi		0 psi to 100 psi		38 psi-low			
	Typ.	Max.	Typ.	Max.	Typ.	Max.	Typ.	Max.	Typ.	Max.	Typ.	Max.		
Span	–	16.7 ± 2	–	50 ± 3	–	100 ± 3	–	100 ± 3	–	100 ± 5	–	39.5 ± 2	mV	1
Null offset	–	0 ± 1.5	–	0 ± 1.5	–	0 ± 1.5	–	0 ± 1.5	–	0 ± 2.0	–	0 ± 1.5	mV	2
Linearity (Best Fit Straight Line, P2 > P1)	0.25	0.5	0.4	0.5	0.25	0.5	0.1	0.2	0.4	0.6	0.1	0.5	%span	3
Null shift (0 °C to 25 °C; 25 °C to 50 °C)	± 0.5	± 1.0	± 0.5	± 1.0	± 0.5	± 1.0	± 0.75	± 1.5	± 1.0	± 0.5	± 0.7	± 1.5	mV	4
Span shift (0 °C to 25 °C; 25 °C to 50 °C)	± 1.0	± 2.0	± 1.0	± 1.5	± 0.75	± 1.5	± 0.75	± 1.5	± 0.5	± 1.5	± 1.0	± 1.5	%span	5
Repeatability and hysteresis	± 0.5	–	± 0.2	–	± 0.2	–	± 0.2	–	± 0.2	–	± 0.2	–	mV	6
Overpressure	–	20	–	20	–	45	–	60	–	200	–	60	psi	7

¹Span is the algebraic difference between the output signal measured at the upper and lower limits of the operating pressure range, where Port 2 (P2) > Port 1 (P1).

²The output signal obtained when zero pressure is applied to all available ports.

³The maximum deviation of product output from a straight line fitted to the output measured over the specified operating pressure range, calculated according to BFLS. The straight line is fitted along a set of points that minimizes the sum of the square of the deviations of each of the points (“least-squares” method),

⁴The maximum deviation in offset due to changes in temperature over the compensated temperature range, relative to offset measured at a reference temperature of 25 °C.

⁵The maximum deviation in span due to changes in temperature over the compensated temperature range, relative to full-scale span measured at a reference temperature of 25 °C.

⁶Repeatability is the maximum difference between the output readings when the same pressure is applied consecutively, under the same operating conditions, with pressure approaching from the same direction within the specified operating pressure range. Hysteresis is the maximum difference between output readings when the same pressure is applied consecutively, under the same operating conditions, with pressure approaching from opposite directions within the specified operating pressure range.

⁷Overpressure is the maximum pressure that may safely be applied to the product for it to remain in specification once pressure is returned to the operating pressure range. Exposure to higher pressures may cause permanent damage to the product. Unless otherwise specified, this applies to all available pressure ports at any temperature within the operating temperature range.

Figure 1. Circuit Diagram

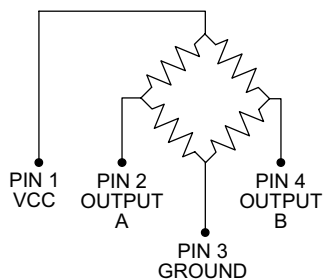

Output “A” increases as P2 pressure increases.

Output “B” decreases as P2 pressure increases.

Symbol	Description
Vcc	supply
OUTPUT A	bridge positive output
GROUND	ground
OUTPUT B	bridge negative output

Miniature Low Pressure Flow-Through Sensors

Figure 2. Nomenclature and Order Guide¹

For example, a **26PCBEG6G** catalog listing defines a 26PC Series Miniature Low Pressure Flow-Through Sensor, Compensated/Unamplified 5 psi pressure range, EPDM seal material, small flow-through pressure port type, 1x 4 SIP/15,2 mm [0.60 in] long termination configuration, normal polarity output, and gage pressure measurement type.

26PC	B	E	G	6G
Product Series	Pressure Range	Seal Material	Pressure Port Type	Termination Configuration, Output, Pressure Measurement Type
26PC Series Miniature Low Pressure Flow-Through Sensors, Compensated/ Unamplified	A 1 psi	F fluorosilicone	G Small flow-through	2G 2 x 2 DIP, normal polarity, gage
	B 5 psi	E EPDM	P Flow-through, long ends,	5G 1 x 4 SIP for wire harness ³ , normal polarity, gage
	C 15 psi	N neoprene ²	U Flow-through, short ends	6G 1 x 4 SIP, 15,2 mm [0.60 in] long, normal polarity, gage
	D 30 psi			
	F 100 psi			
	J 38 psi-low			

¹Every combination may not be possible. Contact customer service.

²Available in 1 psi, 5 psi and 15 psi pressure ranges only.

³Various wire harnesses with end connector options are available. Contact customer service.

Figure 3. All Available Configurations

26PCXXG5G



26PCXXG6G

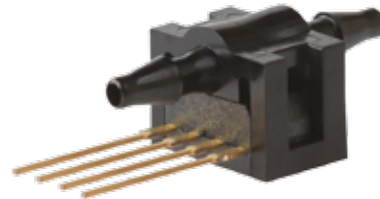

26PCXXP2G

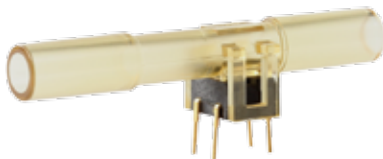

26PCXXP5G



26PCXXU5G



26PC Series, Compensated/Unamplified

Figure 4. Pressure Port Types and Termination Configuration Dimensions (For reference only: mm)

26PCXXG5G

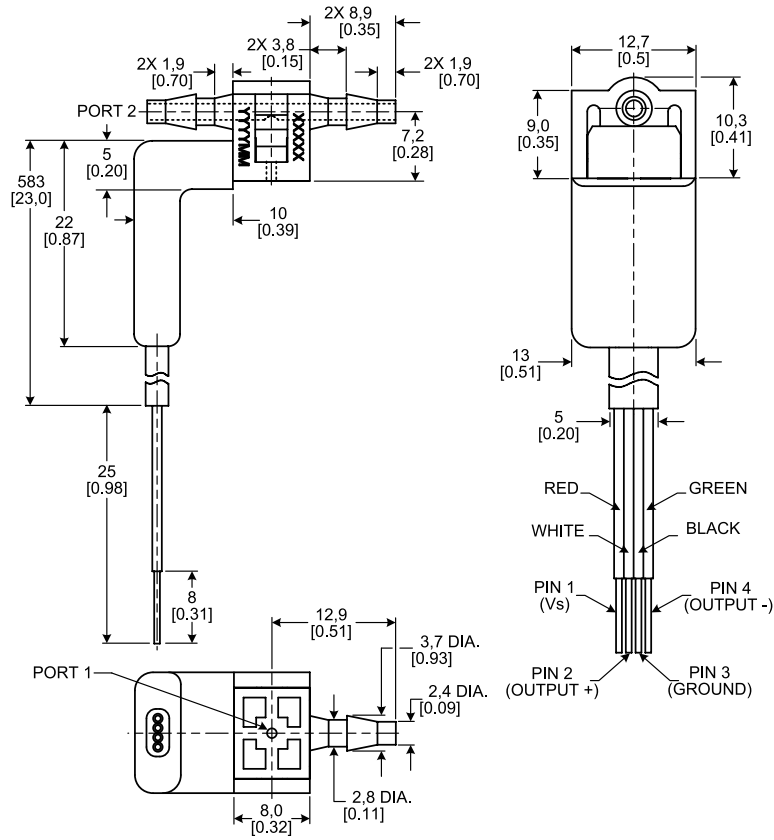

26PCXXG6G

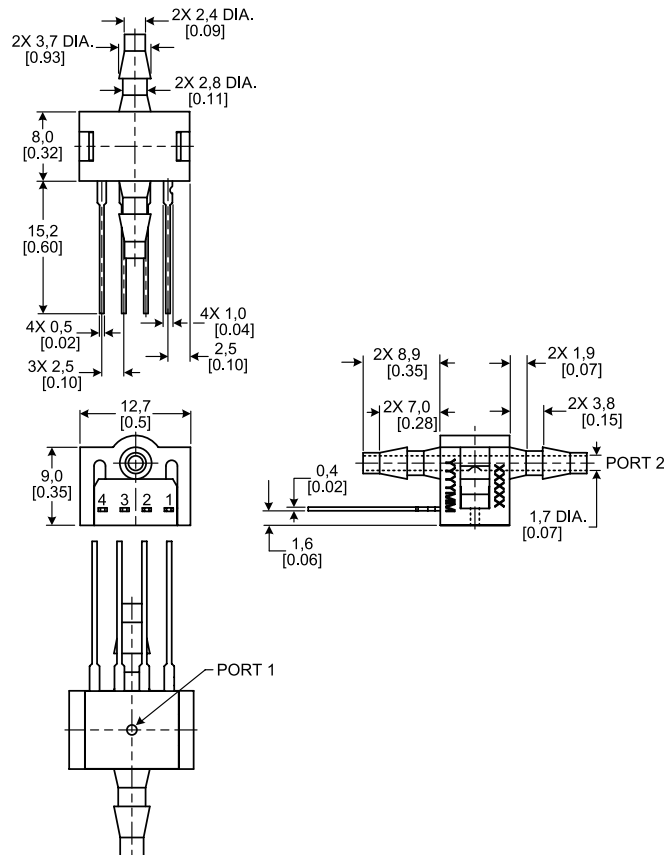

Miniature Low Pressure Flow-Through Sensors

Figure 4. Pressure Port Types and Termination Configuration Dimensions (continued)

26PCXXP2G

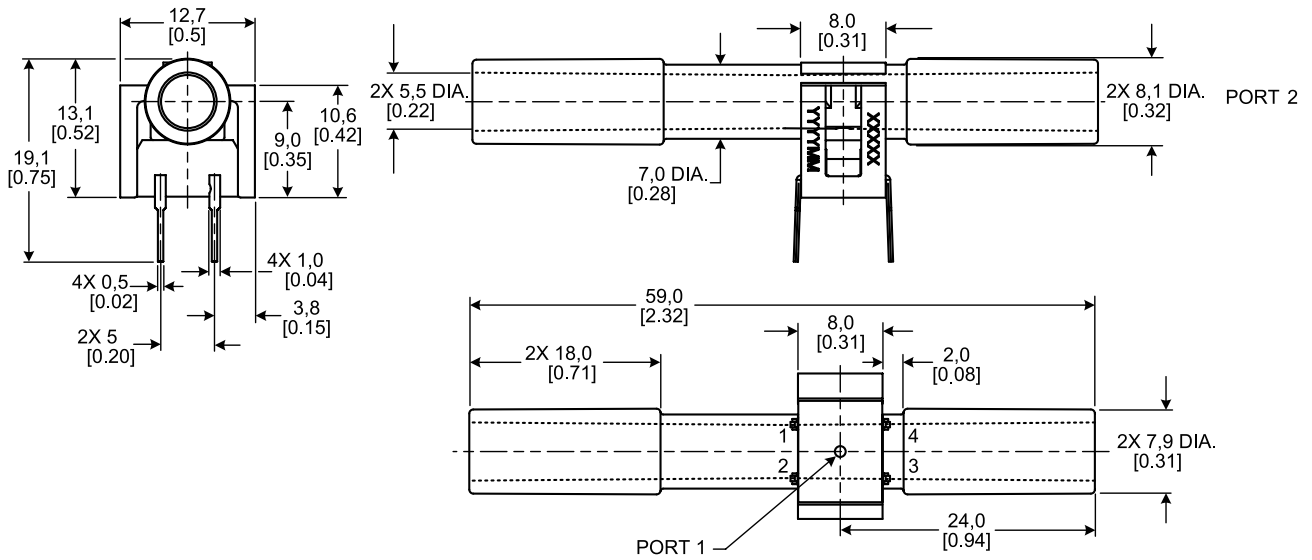

26PCXXP5G

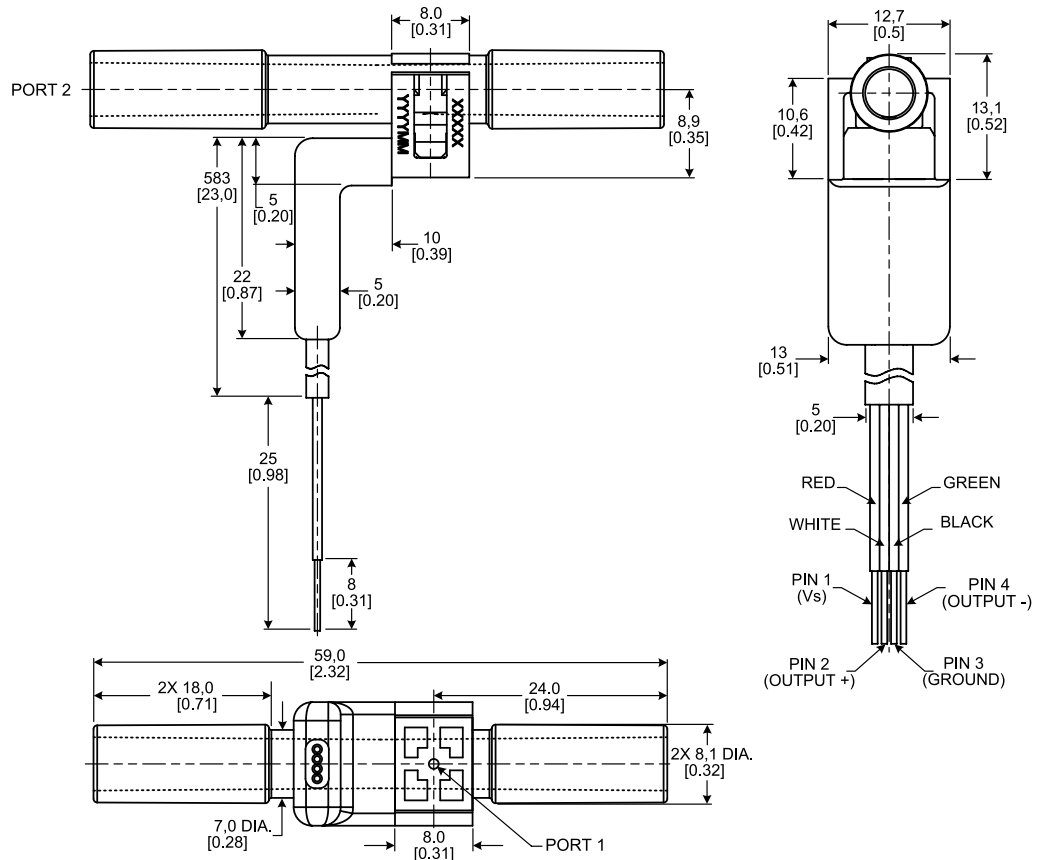

26PC Series, Compensated/Unamplified

Figure 4. Pressure Port Types and Termination Configuration Dimensions (continued)

26PCXXU5G

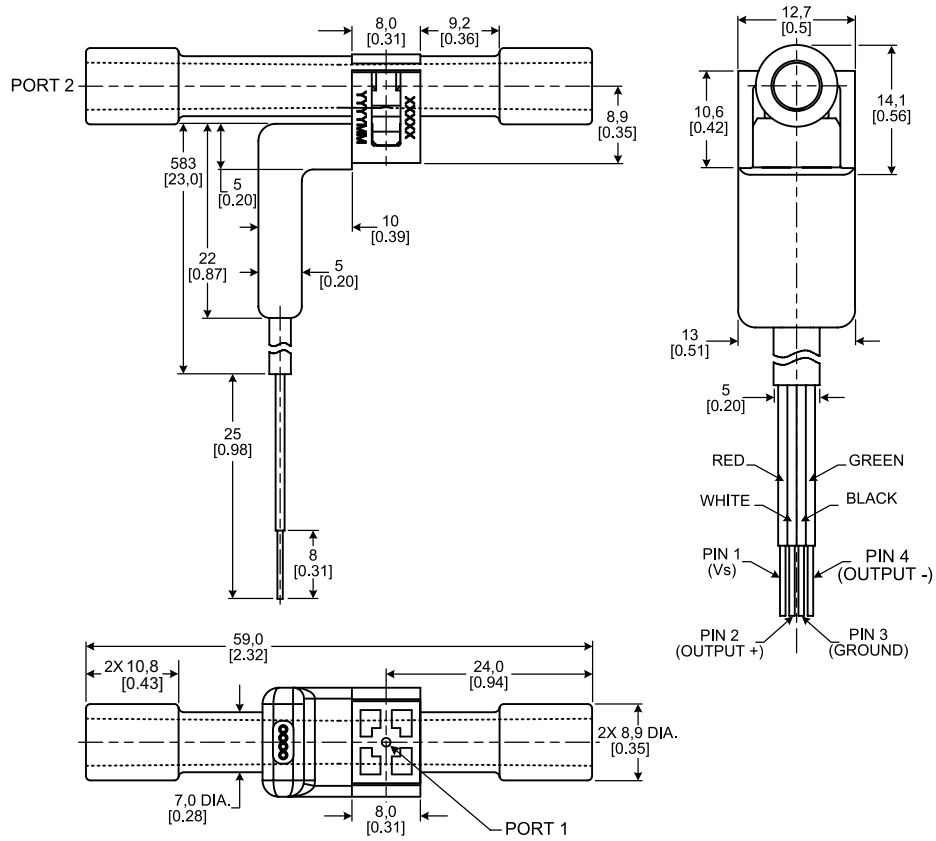

ADDITIONAL INFORMATION

The following associated literature is available at sensing.honeywell.com:

- Product Line Guide
- Product Range Guide
- Product Installation Instructions
- Application-Specific Information
- Technical Information

Find out more

Honeywell serves its customers through a worldwide network of sales offices, representatives and distributors. For application assistance, current specifications, pricing or name of the nearest Authorized Distributor, contact your local sales office.

To learn more about Honeywell's sensing and control products, call **+1-815-235-6847** or **1-800-537-6945**, visit **sensing.honeywell.com**, or e-mail inquiries to **info.sc@honeywell.com**

Sensing and Control
Honeywell
1985 Douglas Drive North
Golden Valley, MN 55422
honeywell.com

⚠ WARNING **PERSONAL INJURY**

DO NOT USE these products as safety or emergency stop devices or in any other application where failure of the product could result in personal injury.

Failure to comply with these instructions could result in death or serious injury.

⚠ WARNING **MISUSE OF DOCUMENTATION**

- The information presented in this product sheet is for reference only. Do not use this document as a product installation guide.
- Complete installation, operation, and maintenance information is provided in the instructions supplied with each product.

Failure to comply with these instructions could result in death or serious injury.

WARRANTY/REMEDY

Honeywell warrants goods of its manufacture as being free of defective materials and faulty workmanship. Honeywell's standard product warranty applies unless agreed to otherwise by Honeywell in writing; please refer to your order acknowledgement or consult your local sales office for specific warranty details. If warranted goods are returned to Honeywell during the period of coverage, Honeywell will repair or replace, at its option, without charge those items it finds defective. **The foregoing is buyer's sole remedy and is in lieu of all other warranties, expressed or implied, including those of merchantability and fitness for a particular purpose. In no event shall Honeywell be liable for consequential, special, or indirect damages.**

While we provide application assistance personally, through our literature and the Honeywell website, it is up to the customer to determine the suitability of the product in the application.

Specifications may change without notice. The information we supply is believed to be accurate and reliable as of this printing. However, we assume no responsibility for its use.

Honeywell